

features



- True RMS measurement
- Low set & High set
- Operation hour recording
- Fault & Trip LED indication
- Trip value recording (3 memory)
- Total trip count information
- Programmable relay output
- Programmable software lock
- Selectable frequency (50 / 60 Hz)
- Auto Z.C.T. connection check (open / short)
- Flush mount

Technical Specification

Technical data / Setting range

TECHNICAL DATA	Measurement	True RMS Ampere
	Power supply	240 V AC (± 10%)
	Rated frequency	50 / 60 Hz
	Output relay / Alarm	5A / 240 V AC
	Tripping contact	SPDT 5A / 240 V AC
	Weight	~320 g
	Operating temp.	0°C ~ +55°C
	Standard	IEC : 61000-4-2/ 4-4 / 4-5 / 255-5:1

SETTING	Current setting $I_{\Delta n} > (A)$	0.03 ~ 30.0 Ampere
	Trip time setting $t > (sec)$	0.05 ~ 20.0 (0.1 sec. step)
	High-set $I_{\Delta n} \gg (A)$	OFF or 5 ~ 50 Ampere (5 Amp. step)
	High-set trip time	Fixed at 30ms

Casing Dimension

35 mm wide DIN Rail mount

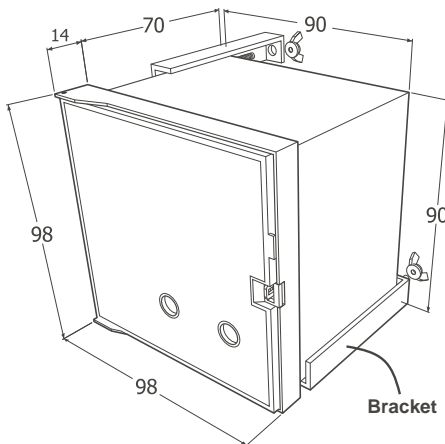
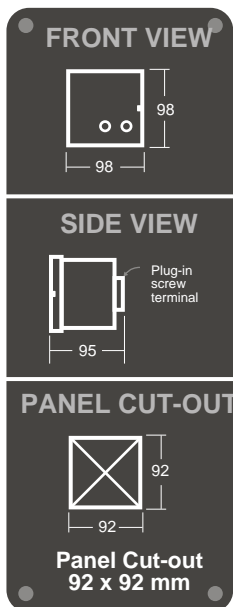

All measurement in millimeters

Panel Description

Overview / Button Functions

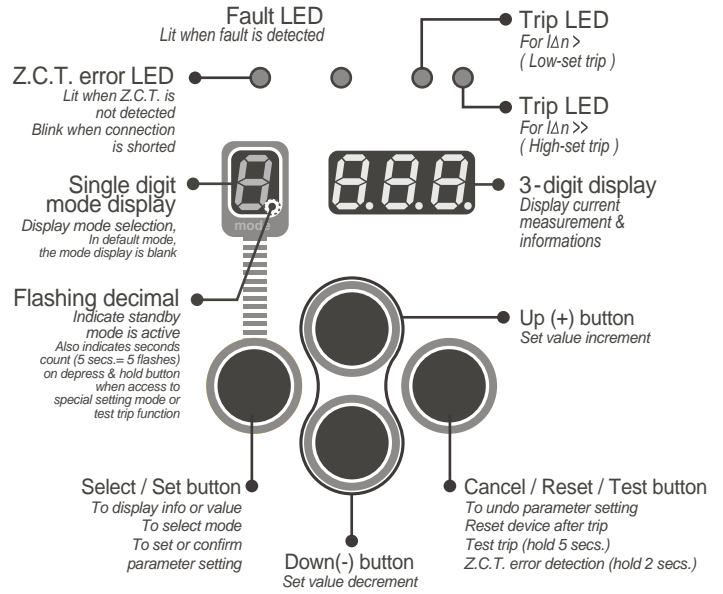

Parameter Modes

Modes definition

mode	description
SETTING	
1 $I_{\Delta n} > (A)$	To set leakage current
2 $t > (sec)$	To set trip time
3 $I_{\Delta n} \gg (A)$	To set high set leakage current
INFO	
9 Operation hr.	Device operated in hours (x 1000 hr.)
8 Trip mem.1	Most recent trip value
7 Trip mem.2	Trip value before (Trip mem.1)
6 Trip mem.3	Trip value before (Trip mem.2)
5 Total trip count	Total number of trips
SPECIAL SETTING MODE	
4 Software lock	Keypad lock : ON or OFF
3 TripRelay K1 response type	Latching or Non-latching
2 Output relay K2 function	Programmable relay output
1 TripRelay K2 response type	Latching or Non-latching
F Network frequency	Selectable as : 50 Hz or 60 Hz
S Standby mode	Running LED bar : ON or OFF
E Z.C.T. error detection	Automatic detection or OFF

Wiring Diagram

Wiring connection

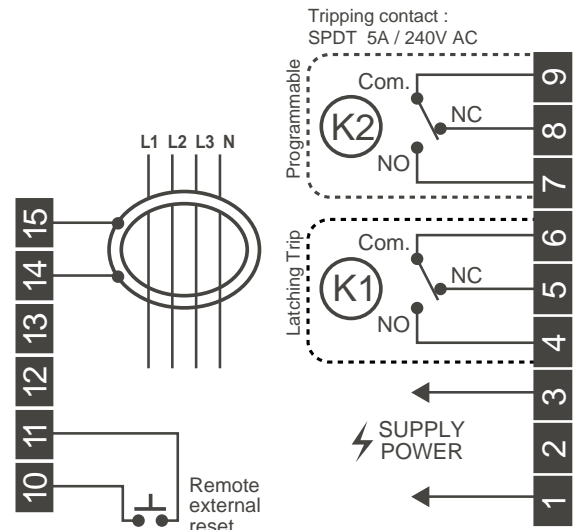

How to do setting

Step by step instruction

When mode display is blank, press [Select] button to access to parameter setting mode.

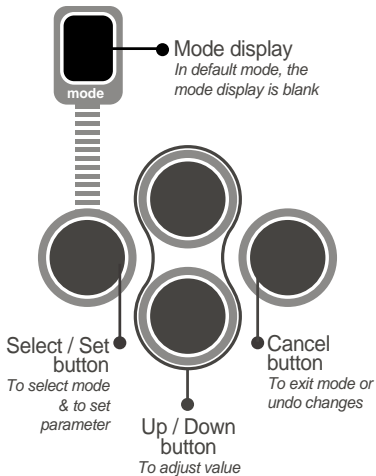

1 Press [Select] button while in default mode to access to parameter setting mode:

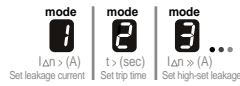

To scroll thru modes, just press & release the [Select] button

2 Press [Up/(+)] or [Down/(-)] button to adjust desire value

For fast increment or decrement, press and hold the UP or Down button

3 Press [Set] to store new value and proceed to the next mode.

Press [Cancel] button to exit mode or undo changes.

All modes exit automatically if left untouched for more than 20 secs.

Setting Parameters

Modes 1 2 3

1 I_{Δn} > (A) : To set leakage current

- Step 1:** Press [Select] once to enter mode 1.
Display will show the existing set value. (Range : 0.03 ~ 30.0 Ampere)
- Step 2:** Set the desired leakage current using the [Up / (+)] or [Down / (-)] button.
Newly selected value will flash.
- Step 3:** Press [Select] to store / confirm new value and advance to mode 2 or press [Cancel] to undo changes.

2 t > (sec) : To set trip time

- Step 1:** Press [Select] until mode 2 is displayed.
Display will show the existing set value. (Range : 0.05 ~ 20.0 seconds)
- Step 2:** Set the desired trip time using the [Up / (+)] or [Down / (-)] button.
Newly selected value will flash.
- Step 3:** Press [Select] to store / confirm new value and advance to mode 3 or press [Cancel] to undo changes.

3 I_{Δn} >> (A) : To set high set leakage current

- Step 1:** Press [Select] until mode 3 is displayed.
Display will show the existing set value. (Range : 5 ~ 50 Ampere or OFF)
- Step 2:** Set the desired high-set leakage current using the [Up / (+)] or [Down / (-)] button. Newly selected value will flash.
- Step 3:** Press [Select] to store / confirm new value and advance to mode 3 or press [Cancel] to undo changes.

Viewing Info

Modes 9 / A B C / d

9 View operation hour x 1000

This mode is not adjustable. For user to view the no. of hour the device in operation. Press [Select] until mode 9 is displayed.
Display will show the total number of hour device operated. To exit, press [Cancel].
e.g. 0.05 x 1000 = 50 hours

A B C View trip memory : 3 tripping memories

This mode is not adjustable. For user to view tripped value only. Press [Select] until mode A is displayed.
The display will show the most recent tripped value.
Press [Select] again to go to mode B, the display will show the tripped value before A.
Press [Select] again to go to mode C, the display will show the tripped value before B.
To exit, press [Cancel].

d View total trip count / To reset total trip count / trip memory

This mode records the total number of tripping that has occurred for the device (maximum = 255). This value cannot be reset by any timer.
Press [Select] until mode d is displayed.
Display will show --- (no tripping has occurred) or a value between 1 to 255.
To exit, press [Cancel] button.

Special Setting Modes

Modes 0 1 2 3 4 5 6 7 8

User can lock the keypad on the device to avoid unauthorized or accidental adjustment to the settings and to do special settings.

When NO mode is selected (mode display is blank),

- Press [Select] and [Cancel] button simultaneously and hold for 5 seconds.
- Press [Up / (+)] or [Down / (-)] button to select or modify
- Press [Set] button to confirm and proceed to next mode

Software keypad lock

0FF : Parameters modification : Allowed
0n : Parameters modification : Not Allowed

1 Trip relay K1 response type

Lc : Latching trip signal
nLc : Non-Latching trip signal

2 Output relay K2 function

ALn : Alarm output (Lc/nLc)
BUP : Device failure output
EL5 : Earth leakage start signal output(nLc)
ERP : Tripping output (Lc/nLc)

2 K2 response type

Lc : Latching trip signal
nLc : Non-Latching trip signal
nA : Not Applicable

F Electrical network system frequency

Electrical network frequency setting:
50 = 50 Hz 60 = 60 Hz

Standby option

0FF : De-activate 0n : Activate

A flashing decimal on the mode display indicate standby mode is enable. After about 3 minutes of idle and no leakage is detected, running LED bar will be displayed instead of the real time leakage current. Standby mode automatically exits on leakage detection or when any button is depressed. When device trips, standby mode is temporary de-activated until device is reset. Alternatively, simply press [Cancel] button when powering up the device to activate or de-activate standby function.

6 Z.C.T error detection

Aut : Automatic check at 2 hour interval
0FF : Disable detection

For manual check, press & hold the [Test] button for 2 secs. If Z.C.T. connection is open or shorted, then the Z.C.T. error LED will lit.

After the Ct mode, the display will show End <-> Set.

Press [Set] to confirm all of the above settings or press [Cancel] to go back one previous mode.

Press & hold [Cancel] for 3 seconds to exit and abort the modification without saving (previous setting unchanged).

New setting only takes effect when [Set] button is pressed during End <-> Set is displayed.

Manual ' test trip '

Test device for fault in tripping

Manual test trip allows the user to test the device for any fault in tripping. To do a manual test trip, follow the instruction below:

When NO mode is selected (mode display is blank),

- Press & hold [Test] button for 5 seconds.
The mode display decimal will flash 5 times to indicate 5 seconds count.
- Release the button when the display show : E-b
- Mode starts to count down from 5 and trips at zero. The display will show : ERP
To abort test when mode has not counted down to zero, press the [Cancel] button.

Reset Trip Memory

Reset recorded trip memories or total trip count

Press [Select] button until mode [A] is displayed.

If the display show --- (NO tripping has occurred), no resetting is required.
If the display show a certain value (tripping has occurred), then follow the steps below:-
Press [Cancel] button and hold for 3 seconds in current mode -> mode 9 or Press [Up] and [Down] button simultaneously and hold for 3 seconds in mode 9.
(The mode display decimal will flash 3 times to indicate 3 seconds count)
The display will reset to show LcLr. To exit, press the [Cancel] button.

Z.C.T. Specification

Zero phase current transformer

For optimum performance and accuracy, we recommend that you use only the original Z.C.T. intended for use with the device. Using others Z.C.T. could compromise on the performance or accuracy. The warranty does not cover product failures which have been caused by use of other Z.C.T.

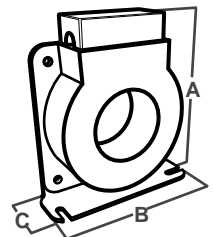

(Type)	ZPC-35	ZPC-50	ZPC-100	ZPC-140	ZPC-200
Hole Diameter (mm)	35	50	100	140	200
A (mm)	82	125	183	235	306
B (mm)	103	112	153	175	255
C (mm)	26	35	35	40	45
Weight (kg)	~0.30	~0.70	~1.40	~2.2	~4.6
Frequency	50 / 60 Hz				
Current Ratio	200 / 1.5				
Insulation	600V / 50 Hz 1 min.				
Sec. Burden	10 VA				

Contact your supplier for more information.